

# L U F T<sup>®</sup>

QUALITY IS NOT EXPENSIVE IT'S PRICELESS

*presenting*

## FUSION CURTAIN MOTOR

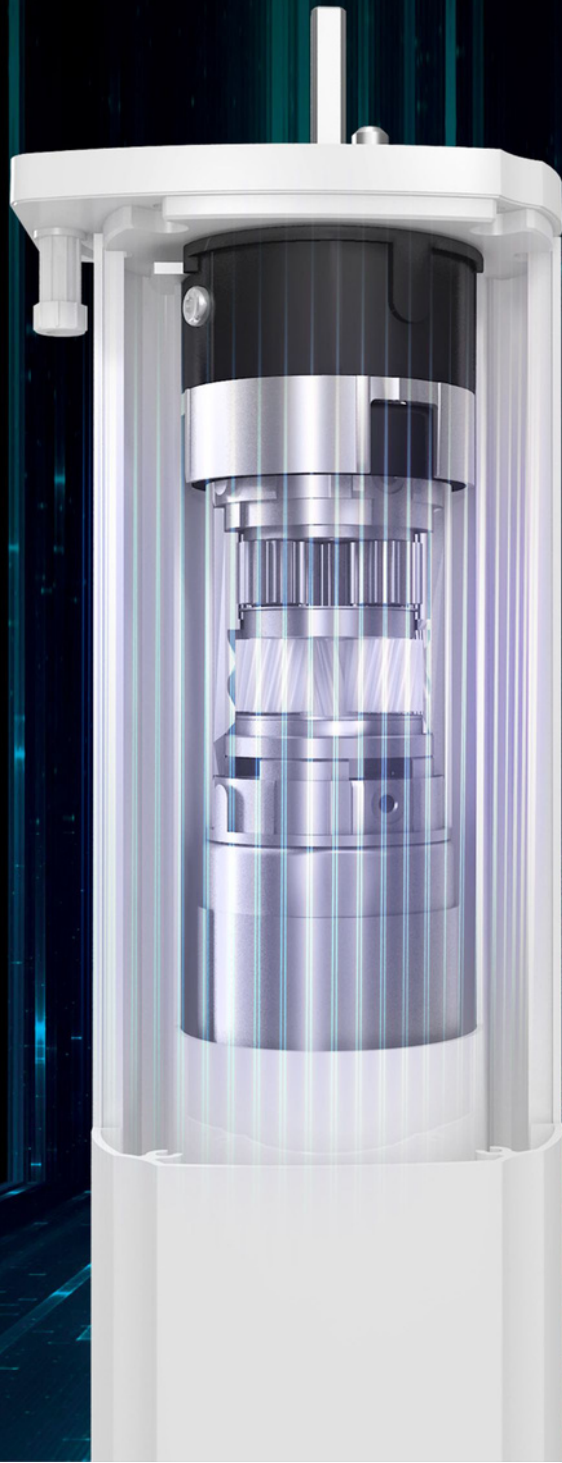



LÜFT®  
ULTRA-QUIET MOTOR COLLECTION

**INDOOR MOTORIZED SHADES SOLUTIONS**

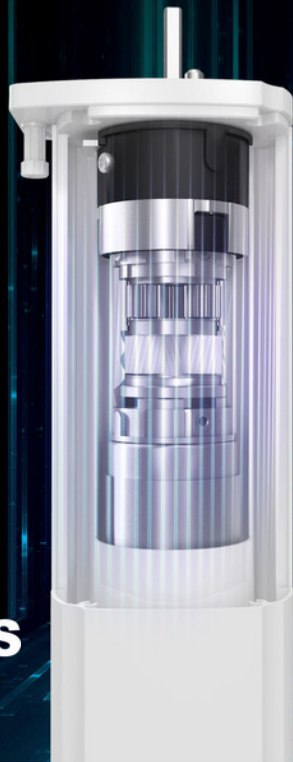

Fusion Curtain Motor comes with advanced technology for Heavier load and quiet operation. It is flexible for manual switch operation meant for automation or wireless remote operation.

PRODUCT NAME	MODEL	RATED TORQUE	SPEED	MOTOR SIZE	RATED VOLTAGE	RATED POWER	IP CLASS
Fusion Curtain Motor (Five Wires)	FCM175	1.5Nm	16cm/s	316x68x53mm (L) (W) (H)	AC100-240V 50/60HZ	65W upto 60kgs	IP20

### FEATURES

- Stop on block
- Soft start and soft stop
- Automatic Limit setting memory
- Flexible super silent design
- Various control options
- Wide Voltage power supply
- Group control
- Fabric rebound journey correction
- Pull to go
- Over-voltage protection
- Manual Switch function

### WIRING INSTRUCTIONS

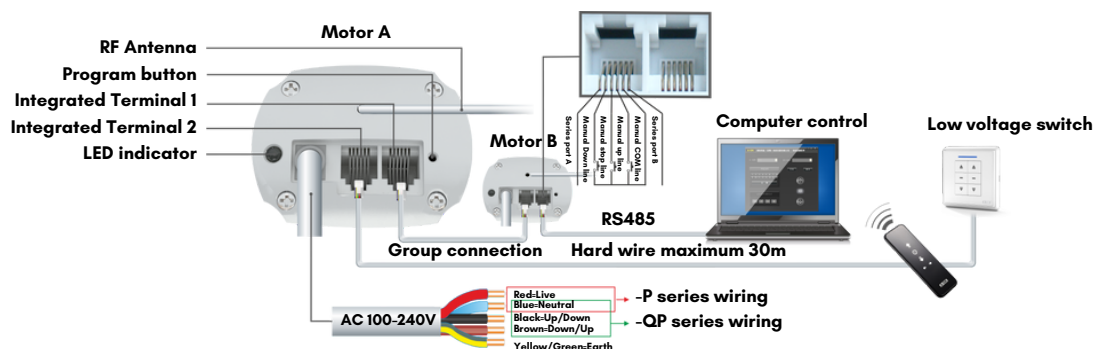

# PREMIUM CURTAIN MOTOR

Using our new generation  
Helical Gearbox Design,  
Fusion Curtain Motor is more  
Powerful & Quiet.



# SHADOW TUBULAR MOTOR

## 35MM/45MM

AUTOMATION/REMOTE CONTROLLED MOTOR



Automation Motor



Remote Controlled Motor

### Applications:



Roller blinds



Wooden venetian



Pleated blinds



Roman blinds



Roller shutter

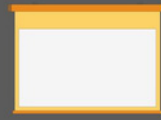

Projection screen

### 35mm

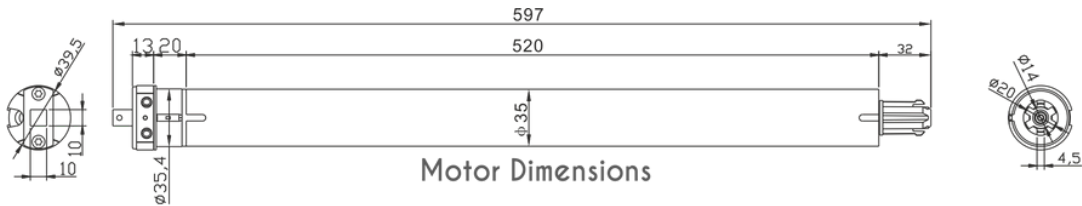

### 45mm

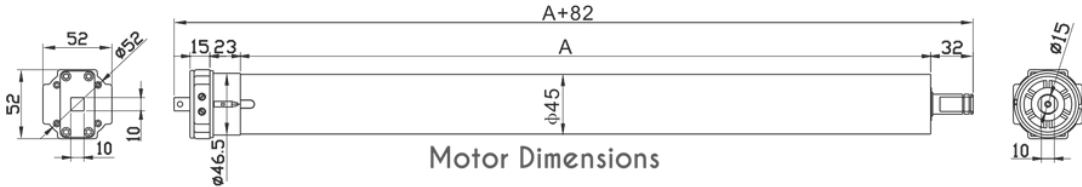

Automation Motor  
STM135-A & STM145-A

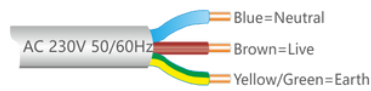

Remote Controlled Motor  
STM135-R & STM145-R



## FEATURES

- AC power supply
- Home Automation Control (STM135-A & STM145-A)
- Mechanical limit
- Built-in receiver (STM135-R & STM145-R)
- Running noise is 40dB for 35mm
- Running noise is 45dB for 45mm
- High anti-interference, receiving sensibility-110dBm
- Built-in receiver, simple installation and stable performance
- High impact resistant relay, industrial-grade CPU
- Working temperature-40~+85°C
- Accurate SMT assembly, damp-proof treatment on surface

## PARAMETERS

Model No.	Rated Torque	Rated RPM	Motor Diameter	Rated Voltage	Rated Power	Rated Current	IP Class	Tube Length A
STM135-A	6N.m	28rpm	35mm	230V	115W upto 17kgs	0.485A	IP44	
STM135-R	6N.m	28rpm	35mm	230V	115W upto 17kgs	0.485A	IP44	
STM145-A	20N.m	17rpm	45mm	230V	170W upto 44kgs	0.735A	IP44	585mm
STM145-R	20N.m	17rpm	45mm	230V	170W upto 44kgs	0.735A	IP44	585mm

# REMOTES & ACCESSORIES

LMR-101  
SINGLE CHANNEL



LMR-102  
DOUBLE CHANNEL



LMR-106  
SIX CHANNEL



LMR-101 LMR-102 LMR-106

## FEATURES

- ✓ Luxurious piano lacquer, Anti-scratch surface treatment
- ✓ Low battery consumption.
- ✓ Simple design with touch screen.
- ✓ Advanced touch technology.
- ✓ Cr2032 button battery, can be easily replaced.
- ✓ Battery last for 2-3 years.



SCAN QR CODE TO DOWNLOAD E-CATALOGUE

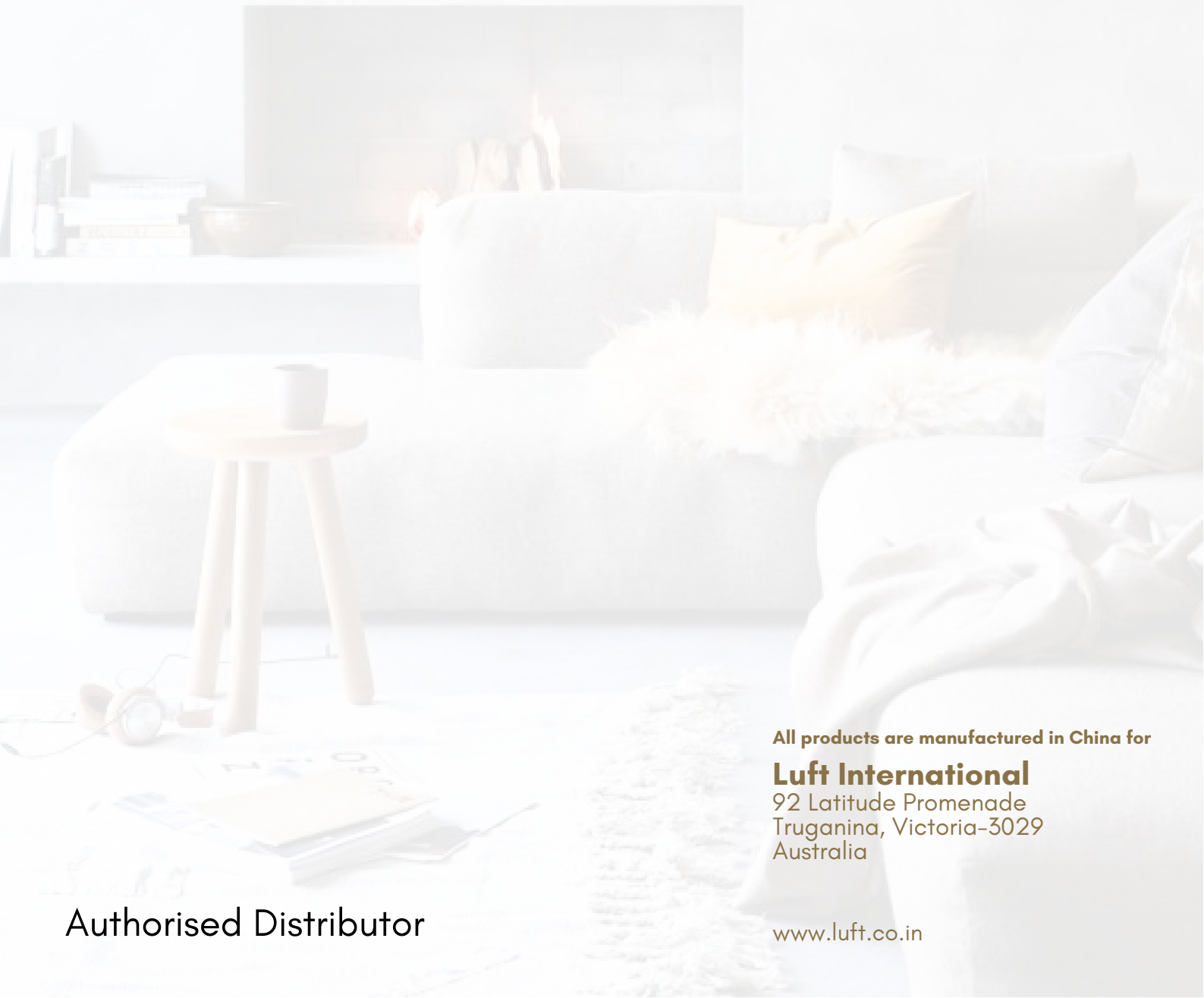

All products are manufactured in China for

**Luft International**

92 Latitude Promenade  
Truganina, Victoria-3029  
Australia

Authorised Distributor

[www.luft.co.in](http://www.luft.co.in)